

2.0 A Surface Mount Fast Recovery Rectifier
Rectifier Reverse Voltage 50 to 800V

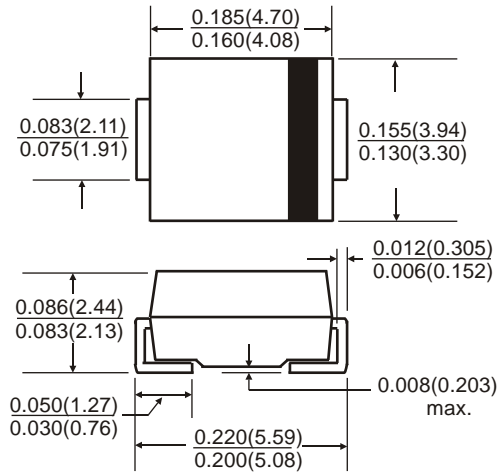

SMB / DO-214AA



All dimensions inches and (millimeters)

Features

- Ideal for surface mounted applications
- Fast switching for high efficiency
- High current capability and low Forward Voltage Drop
- Surge overload rating to 50A peak
- Low reverse leakage current
- Plastic material has UL flammability classification 94V-0

Mechanical Data

Case: Molded plastic
 Terminals: Solder plated solderable per MIL-STD-202, Method 208
 Polarity: Cathode indicated with color band
 Weight: 0.093 grams (approx)

Maximum Ratings & Thermal Characteristics

Rating at 25°C ambient temperature unless otherwise specified, Resistive or Inductive load, 60 Hz.
 For Capacitive load derate current by 20%.

Parameter	Symbol	FR2A	FR2B	FR2D	FR2G	FR2J	FR2K	unit
Maximum repetitive peak reverse voltage	VRRM	50	100	200	400	600	800	V
Maximum RMS bridge input voltage	VRMS	35	70	140	280	420	560	v
Maximum DC blocking voltage	VDC	50	100	200	400	600	800	v
Maximum average forward rectified output current at TL=90°C	IF(AV)	2.0						A
Peak forward surge current single sine-wave superimposed on rated load (JEDEC Method)	IFSM	50.0						A
Maximum reverse recovery time TJ=25°C	Trr	150				250	500	nS
Typical thermal resistance per element	ReJA	50						°C/W
Typical junction capacitance per element	Cj	15						pF
Operating junction and storage temperature range	TJ, TSTG	-55 to + 150						°C

Electrical Characteristics

Rating at 25°C ambient temperature unless otherwise specified. Resistive or Inductive load, 60Hz.
 For Capacitive load derate by 20 %.

Parameter	Symbol	FR2A	FR2B	FR2D	FR2G	FR2J	FR2K	Unit
Maximum instantaneous forward voltage drop per leg at 2.0A	VF	1.3						V
Maximum DC reverse current at rated DC blocking voltage per element	IR	5.0				50		µA

Rating and Characteristic Curves (TA=25°C Unless otherwise noted) FR2A thru FR2K

Fig. 1 Reverse Recovery Time and Test Circuit Diagram

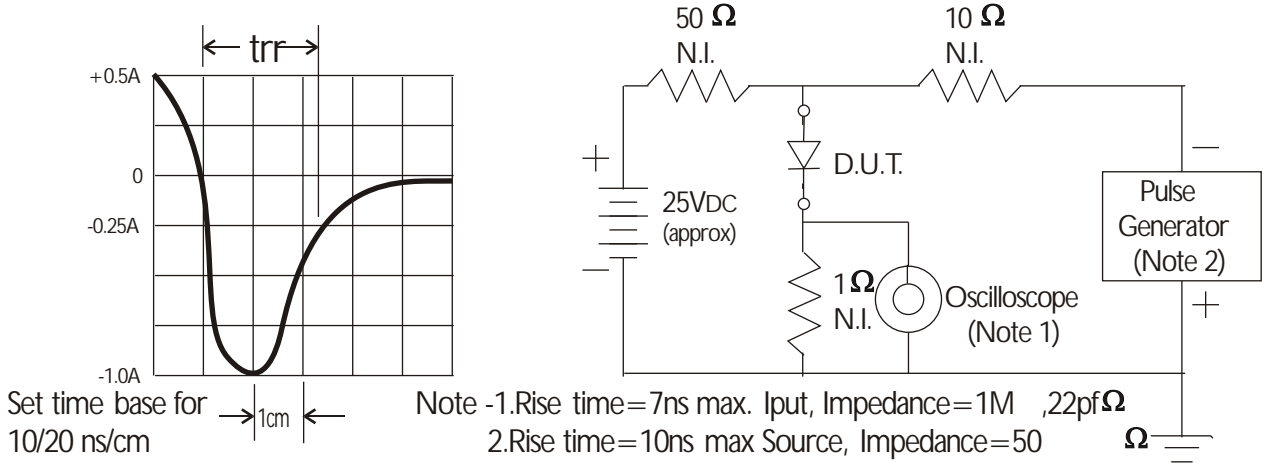

Fig. 2 Derating Curve for Output Rectified Current

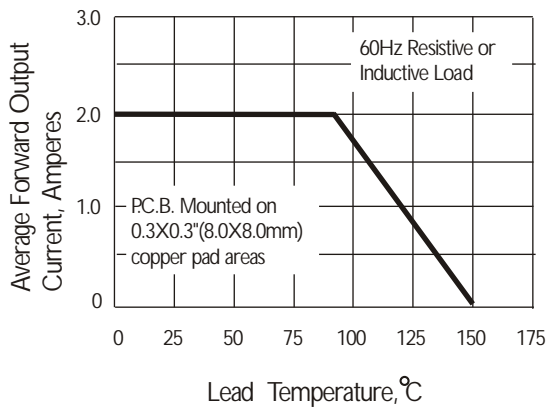

Fig. 3 Peak Forward Surge Current

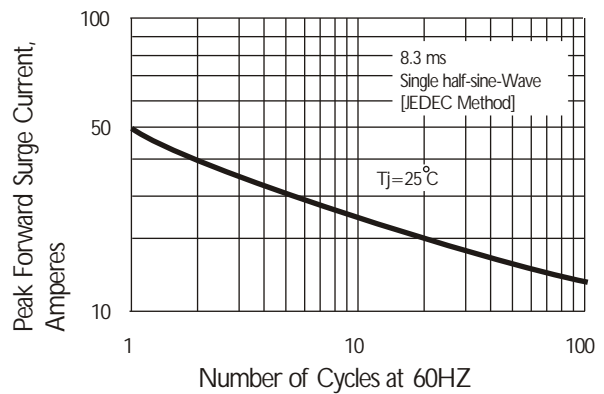

Fig. 4 Typical Instantaneous Forward Characteristics

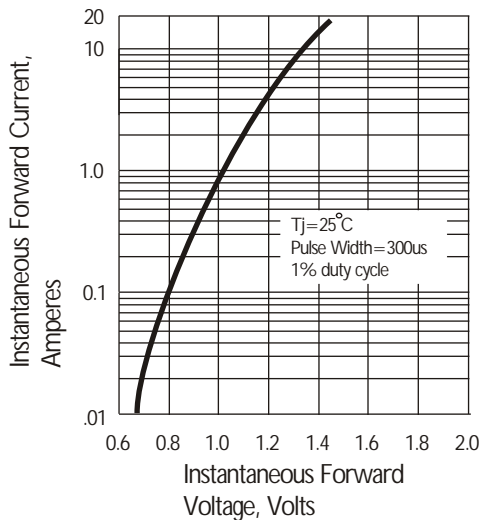

Fig. 5 Typical Junction Capacitance

